

Specification sheet LX 1347

Parapet drainage Series 43 LORO-X DUOFLUX® Pipe in pipe - with basin -

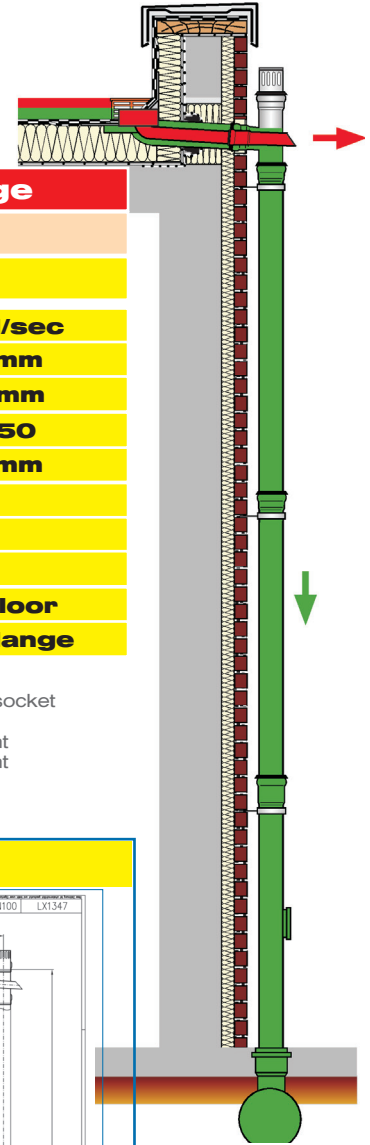

Main drainage	Emergency drainage
Gravity flow	Gravity flow
Silent Power	Silent Power
Discharge rate: 3,7 l/sec	Discharge rate: 3,0 l/sec
Water height: 35 mm	Water height: 75 mm
Roof penetration: 103 mm	Roof penetration: 103 mm
Diameter: DN 100	Diameter: DN 50
Weir height: 0 mm	Weir height: 40 mm
Drain: ventilated	Drain: ventilated
Downpipe: ventilated	Downpipe: ventilated
Downpipe height: 4,2 m	Downpipe height: 0 m
Drainage: in sewer	Drainage: on floor
Flange form: Bonding flange	Flange form: Bonding flange

LX 1347 Piece list

- 1 x Art.-No. 13508.100X, LORO-X DUOFLUX® Pipe in Pipe
- 1 x Art.-No. 01211.100X, LORO-X Pipe with one socket
- 1 x Art.-No. 01203.050X, LORO-X Pipe with one socket
- 1 x Art.-No. 13519.DB0X, LORO-Branch pipe in pipe
- 1 x Art.-No. 13235.100X, LORO-X Sliding flange
- 2 x Art.-No. 00806.100X, LORO-X Anchor clips
- 2 x Art.-No. 13217.100X, LORO-X Ventilation piece

- 1 x Art.-No. 01001.100X, LORO-X Pipe with one socket
- 1 x Art.-No. 05515.100X, LORO-X Stand pipe
- 4 x Art.-No. 00911.100X, LORO-X Sealing element
- 2 x Art.-No. 00911.050X, LORO-X Sealing element
- 3 x Art.-No. 00975.100X, LORO-X Pipe clamps
- 3 x Art.-No. 09604.200X, LORO-X Threaded rods
- 1 x Art.-No. 00986.000X, LORO-X Lubricant

hQ-dB - Head-Discharge curve

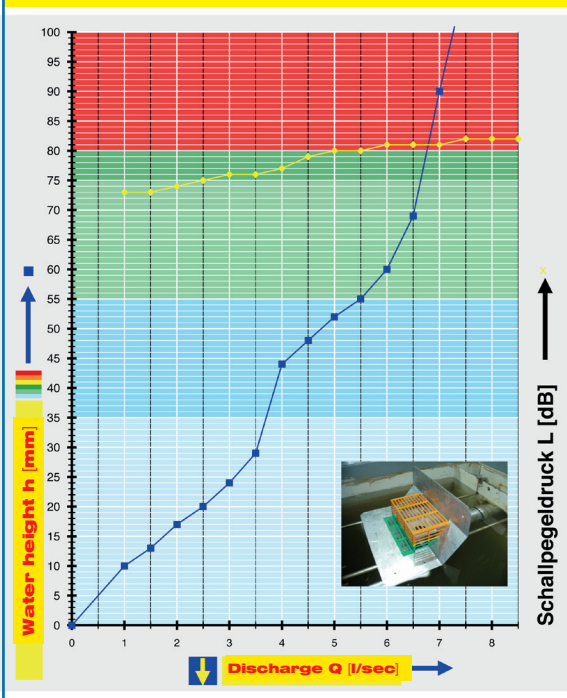

Systempower

CAD

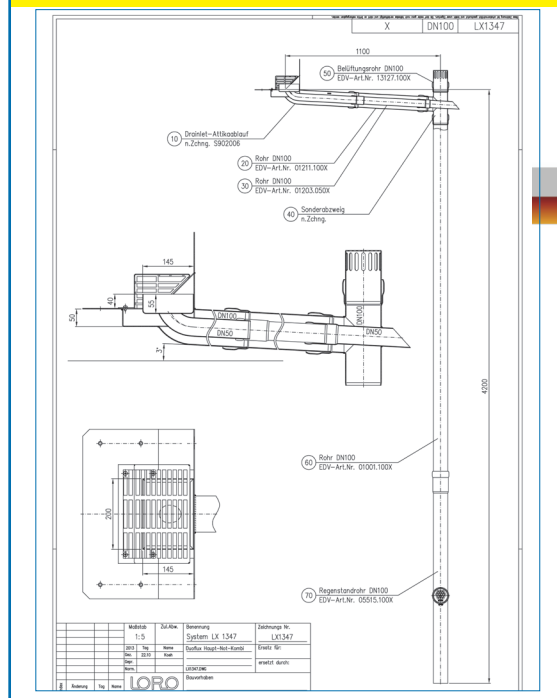

Systemshape

Water height	mm	10	15	20	25	30	35	40	45	50	55	60	65	70	75
Discharge	l/sec	1,0	1,7	2,5	3,1	3,5	3,7	3,8	4,1	4,7	5,5	6,0	6,2	6,5	6,7
Silent															

LORO-X DUOFLUX[®] Main emergency combination Parapet drain,

LX1347-3X

Series 43

Drain: Art.-No. 13508.100X

Weight: 9,6 kg

with bonding flange
for bituminous roofing sheets

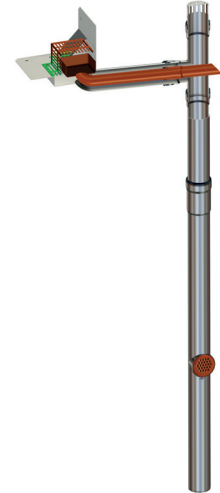
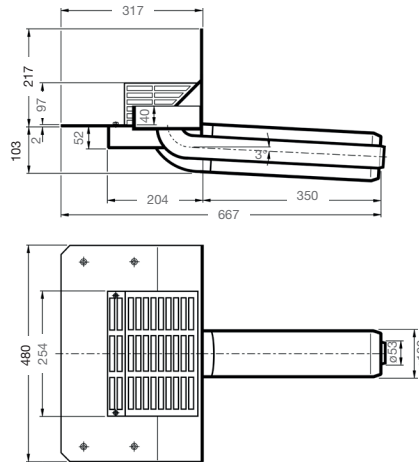
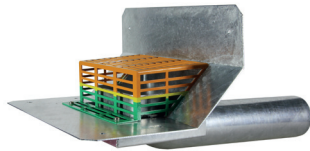

LORO-X Branch pipe in pipe, DN 100/50, spout

for LORO-X DUOFLUX[®] Parapet drain,
made of hot-dip galvanised steel, DN 100/50

Art.-No. 13519.DB0X

Weight: 3,5 kg



LORO-X Vent piece with perforated sheet

for LORO-X DUOFLUX[®] Parapet drain,
made of hot-dip galvanised steel

article No. 13217.100X

Weight: 0,7 kg



LORO-Stand pipe with cleaning opening, DN 100

made of hot-dip galvanised steel, DN 100

Art.-No. 05515.100X

Weight: 6,6 kg

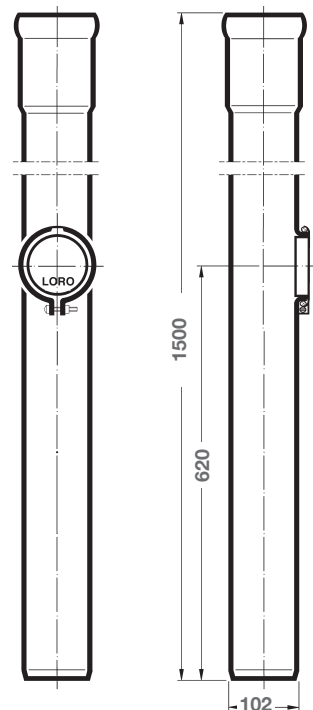

Heat tracing: LOROWERK recommends to check all drains and pipes with regard to their frost-sensibility. Where necessary, these parts should be upgraded with heat tracing.